

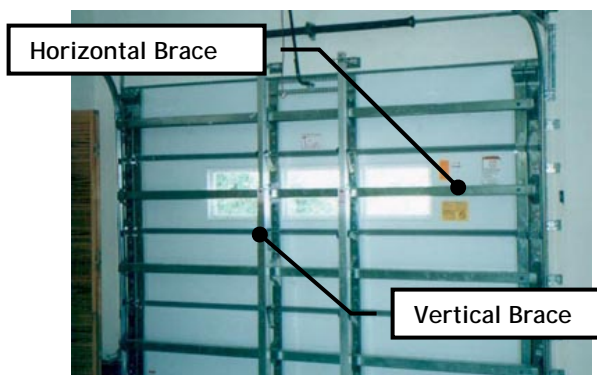

## Brace or Replace Garage Doors

If you live in an older house you may need to brace or replace your garage door. Existing doors can be reinforced with horizontal bracing positioned at the center of each door panel row.

You may also need the additional strength provided by removable vertical bracing spaced across the span of the door and anchored into the floor and roof trusses.



Source: St. Lucie County Extension

The garage door track is another common area in need of reinforcement. As shown in the figure on the bottom right of this page, an unreinforced track can bend allowing the garage door to break free from the wall.

## Additional Issues to Consider

Sometimes retrofitting existing garage doors to improve high wind resistance can be a difficult task. It may be worthwhile to hire a qualified contractor to install the necessary bracing or even to install a new hurricane resistant garage door.

Should you choose to make these garage door improvements on your own, remember that the new bracing may increase the weight of your door. This may require the replacement of the garage door motor.

When bracing existing garage doors, remember to cover any windows on the door panels with shutters to protect the glass. Avoid purchasing new garage doors with windows.

If maximum protection is your goal, be sure to select products approved by the very thorough Miami-Dade County standards (see product search link below).

## Other Resources

Federal Alliance for Safe Homes

[www.flash.org](http://www.flash.org)

Federal Emergency Management Agency |  
Disaster Prevention & Preparation Library  
[www.fema.gov/library/prepandprev.shtm](http://www.fema.gov/library/prepandprev.shtm)

Institute for Business and Home Safety

[www.ibhs.org](http://www.ibhs.org)

Miami-Dade County | Building Code  
Compliance Product Search

[http://www.miamidade.gov/buildingcode/online\\_product\\_search.asp](http://www.miamidade.gov/buildingcode/online_product_search.asp)

### PROBLEM

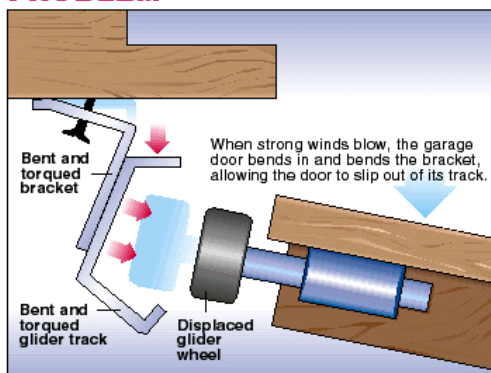

### SOLUTION

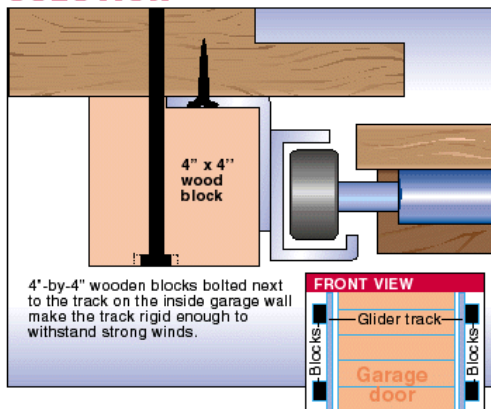

Source: Bryant Fukutomi, Honolulu Star-Bulletin